

(12) INTERNATIONAL APPLICATION PUBLISHED UNDER THE PATENT COOPERATION TREATY (PCT)

(19) World Intellectual Property Organization  
International Bureau



(43) International Publication Date  
16 May 2002 (16.05.2002)

PCT

(10) International Publication Number  
**WO 02/38055 A2**

(51) International Patent Classification<sup>7</sup>: **A61B 17/11**

(21) International Application Number: PCT/NL01/00815

(22) International Filing Date:  
9 November 2001 (09.11.2001)

(25) Filing Language: English

(26) Publication Language: English

(30) Priority Data:  
09/708,617 9 November 2000 (09.11.2000) US

(71) Applicants and

(72) Inventors: **SUYKER, Wilhelmus, Joseph, Leonardus** [NL/NL]; Zalmkolk 13, NL-8017 PB Zwolle (NL).  
**SUYKER, Paulus, Thomas, Wilhelmus** [NL/NL]; Singel 208 F, NL-1016 AA Amsterdam (NL).

(74) Agent: **METMAN, Karel, Johannes**; De Vries & Metman, Overschiestraat 180, NL-1062 XK Amsterdam (NL).

(81) Designated States (*national*): AE, AG, AL, AM, AT, AT (utility model), AU, AZ, BA, BB, BG, BR, BY, BZ, CA,

CH, CN, CO, CR, CU, CZ, CZ (utility model), DE, DE (utility model), DK, DM, DZ, EC, EE, ES, FI, GB, GD, GE, GH, GM, HR, HU, ID, IL, IN, IS, JP, KE, KG, KP, KR, KZ, LC, LK, LR, LS, LT, LU, LV, MA, MD, MG, MK, MN, MW, MX, MZ, NO, NZ, PH, PL, PT, RO, RU, SD, SE, SG, SI, SK, SK (utility model), SL, TJ, TM, TR, TT, TZ, UA, UG, US, UZ, VN, YU, ZA, ZW.

(84) Designated States (*regional*): ARIPO patent (GH, GM, KE, LS, MW, MZ, SD, SL, SZ, TZ, UG, ZW), Eurasian patent (AM, AZ, BY, KG, KZ, MD, RU, TJ, TM), European patent (AT, BE, CH, CY, DE, DK, ES, FI, FR, GB, GR, IE, IT, LU, MC, NL, PT, SE, TR), OAPI patent (BF, BJ, CF, CG, CI, CM, GA, GN, GQ, GW, ML, MR, NE, SN, TD, TG).

**Published:**

— without international search report and to be republished upon receipt of that report

*For two-letter codes and other abbreviations, refer to the "Guidance Notes on Codes and Abbreviations" appearing at the beginning of each regular issue of the PCT Gazette.*

(54) Title: CONNECTOR, APPLICATOR AND METHOD FOR MECHANICALLY CONNECTING HOLLOW STRUCTURES, IN PARTICULAR SMALL BLOOD VESSELS, AS WELL AS AUXILIARY DEVICES

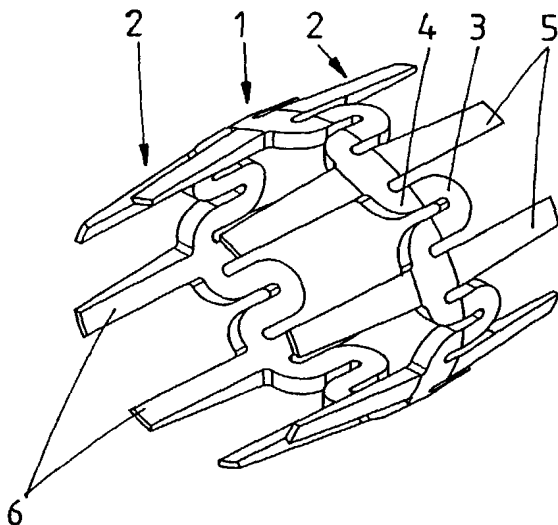

(57) Abstract: The invention relates to a connector (1), applicator and method for mechanically connecting hollow structures, in particular small blood vessels, in order to make an anastomosis. The connector incorporates various features to create a reliable engagement with the vessel walls to make a good connection thereof. The applicator may comprise knife members to make an arteriotomy and punch a hole in one of the vessel walls, comprises an expansion portion to cause a large expansion with a minimum profile, and comprises anvil members to reliably bring staple-like elements (5) of the connector to the joining position. The invention also includes auxiliary devices such as a punch and deforming instrument.



WO 02/38055 A2

Connector, applicator and method for mechanically connecting hollow structures, in particular small blood vessels, as well as auxiliary devices

The present invention relates to a connector and applicator for mechanically connecting hollow structures, in particular small blood vessels, through so called anastomoses. Such means may for example be used when making a bypass past  
5 narrowings or occlusions of arteries caused by arteriosclerosis.

One such connector and applicator are known from WO-A-99/21491 of applicants. This document discloses several embodiments of connectors which are made up of an annular  
10 member and circumferentially spaced joining means for holding the vessel walls together in order to make the joint between the vessels. The connectors as disclosed are suitable both for end-to-side and side-to-side anastomoses.

The object of the present invention is to further  
15 improve the connector and applicator for making mechanical connections between hollow structures.

To obtain this object, the present invention provides a connector for mechanically connecting hollow structures, in particular small vessels, comprising:

20 an annular member of deformable material, said member having a center line and being adapted to be permanently deformed by expansion from a first size in a starting position in which it is delivered to a desired anastomoses site, to a second, larger size in a joining position in which it connects  
25 the hollow structures, and

circumferentially spaced means for joining abutting walls of the hollow structures together, said means including staple-like elements being adapted to be permanently deformed from a starting position in which the connector is delivered to  
30 a desired site, to a joining position in which they engage the hollow structures to connect them, said staple-like elements having at least two free ends and being attached to the annular

member between its free ends and being tapered from the annular member towards their free ends.

This connector according to the invention has various advantages. The expandability of the annular member is  
5 advantageous because, as a result, the size of the connector is small during delivery, while the expansion, which results in a radially outward movement of the staple-like elements before or during deformation into their joining position, helps to  
10 predictably position the tissue of the vessel walls between the free ends of the joining means. Moreover, the size of the annular member can be adapted to the size of the vessels on the site of the anastomosis. The staple-like elements are very suitable for holding together adjacent vessel walls of the vessels to be connected. Due to the tapering, the  
15 predictability of the plastic deformation, which is required to close the staples, is improved. If the staples should be curved according to a certain curvature, the deformation will start at the tips and progress towards the annular member, which leads to a predictable deformation. The tapering can take various  
20 forms. The staple-like elements may for example be conically or wedge-shaped towards the free ends. Preferably, the radial thickness of the staple-like elements is diminished towards the respective free ends, but also the width may be tapered.

In a preferred embodiment, the staple-like elements  
25 are substantially straight and parallel to the center line of the annular member. With this arrangement, the connector can have a minimum diameter which facilitates easy handling during an operation. From this straight starting position, the staple-like elements can be deformed either to a C-shape to form a  
30 perfect or overlapping circle, or to a B-shape or an overlapping B-shape.

In order to further increase the predictability of the deformation phase of the staple-like elements, the staple-like elements may be provided with extreme tips which are preformed  
35 into the anticipated curve of the deformation to the joining position.

It is not necessary that the portions of the staple-like elements on either side of the point of attachments to the

annular member are mirror shaped. The length, thickness and slope towards the free ends can be varied to accommodate required bending characteristics or vessel wall thicknesses.

It is preferred to make the connector according to the invention from one piece of material, preferably metal, for example stainless steel 316L or titanium. Connectors which are sufficiently small for use in coronary artery bypass surgery can be manufactured from one piece of metal by using a combination of cutting with a lathe or rolling and subsequently using laser techniques or electric erosion techniques. In this way, the connector is made directly in 3D. Alternatively, 2D-techniques like photo-etching or electroplating can be used to make 2D pieces out of thin, flat material. These can be converted into 3D, either by forcing a 2D shape into 3D, or by bending and welding together the beginning and end of the 2D shape.

An easily expandable annular member is obtained if the annular member is made up from a continuous elongated piece of material having a sinusoidal pattern meandering about a circle line through the annular member. In this case, the staple-like elements are preferably formed at an apex of the sinusoidal pattern.

In order to increase the maximum size of the annular member in the joining position, it could be advantageous to have the main plane of the annular member at an angle to the center line of the annular member.

Due to this feature, the orifice area of the anastomosis can be increased without increasing the size of the connector and applicator, which is limited by the diameter of the hollow structures through which the applicator is inserted. The above feature results in an elliptical anastomosis with an increased orifice area as compared to a circular anastomosis, while the size of the applicator can remain unchanged. In case the main plane of the annular member is at an angle of for example  $45^\circ$ , the area is increased by a factor  $\sqrt{2} = 1.41$ . Practically the staple-like elements of the connector will remain parallel to the center line of the applicator and connector.

The present invention also includes an applicator for delivering and deploying a connector for mechanically connecting hollow structures, comprising:

a shank-like element;

5 a head formed at a distal end of the shank-like element, said head being adjustable in such a manner that the annular member and the staple-like elements of the connector are deformed from the starting position to the joining position when said adjusting takes place,

10 said head including an inner member and an outer member which are longitudinally slidable and include longitudinally opposite anvil formations which are movable to and from upon relative sliding movements of the inner and outer members in order to deform the staple-like elements to their  
15 joining position;

wherein both the inner and outer members are expandable to deform the connector to the joining position.

Due to the expandability of both the inner and outer members, it is possible to minimize the radial dimensions of  
20 the applicator. It is now possible to make the head of the applicator smaller than the radial size of the connector in the joining position, since the outer member of the head of the applicator is enabled to expand together with the connector.

A simple manner to obtain the expandability of the  
25 inner and outer members is to slit or cut them in axial direction. Preferably, the outer member includes at least first slits and second slits, said first slits are arranged at an end of the outer member which forms part of the head and extends between the anvil formations, said second slits being spaced  
30 from said end of the outer member, and alternate with the first slits and are configured in overlapping arrangement.

Due to this configuration of the slits or cuts, the radial as well as the tangential stiffness of the delicate material between the slits is increased. This further assists  
35 in diminishing the dimensions of the head of the applicator.

Another advantageous feature to minimize the radial dimensions of the head is the feature that the anvil formations, on their sides facing each other, have curved

surfaces dictating the deformation of the staple-like elements, said curved surfaces being formed to such an extent that they terminate at an angle to the longitudinal axis of the head which is slightly beyond 90°, for example 91°-120°.

5           These "low profile" anvil formations make the applicator head as slender as possible, but nonetheless allow for a predictable bending of the staple-like elements of the connector.

10           An alternative applicator according to the invention comprises a shank-like element, and a head formed at a distal end of the shank-like element, said head being adjustable in such a manner that the annular member and the staple-like elements of the connector are deformed from the starting position to the joining position when said adjusting takes  
15 place. The head includes an inner member and an outer member which are longitudinally slidable and include longitudinally opposite anvil formations which are movable to and from upon relative sliding movements of the inner and outer members in order to deform the staple-like elements to their joining  
20 position. The head further includes an expansion member comprising wedges adapted to slide underneath the annular member.

25           In this embodiment of the applicator according to the invention, the expansion of the annular member of the connector is effected by the wedges of the expansion member which slide underneath the annular member and thereby urging the annular member outwardly.

30           One way of enabling the wedges to slide underneath the annular member is to make the expansion member slidable relative to the inner and outer members, and in this embodiment it is advantageous if the wedges are interleaved with the anvil formations, since the head of the applicator can then be made as small as possible.

35           In this embodiment of the applicator, the simplest design thereof is obtained if the staple-like elements are first deformed to their joining position, whereafter the annular member is expanded by the wedges of the expansion member. In that case it is not necessary to make the outer

member expandable and in a preferred embodiment it is even possible to expand the annular member of the connector and remove it from the head of the applicator in distal direction over the anvil formations of the inner member in a continued  
5 operation.

In another embodiment of the applicator according to the invention, the head includes not only an anastomosis portion which is adjustable in such a manner that the annular member and the joining elements of the connector are deformed  
10 from the starting position to the joining position when said adjusting takes place, but also a punching portion distally of the anastomosis portion and including two relatively movable parts configured to cause a punching action on a wall of the hollow structure and to catch or trap a punched-out part of  
15 said wall.

With such applicator it is possible to both cut a hole in the vessel wall in order to enable the applicator to enter the vessel, and to perform the anastomosis with the same instrument. This simplifies the procedure and reduces time and  
20 cost.

The invention further includes a method of delivering and deploying a connector for mechanically connecting hollow structures. This method comprises the steps of:

25 providing a connector for joining adjacent walls of the hollow structures,

providing an applicator for said connector, said applicator including cutting means,

making an arteriotomy in the wall of one of the hollow structures,

30 inserting the cutting means of the applicator partly into said one of the hollow structures through the arteriotomy, so as to cut a hole in the wall,

advancing the applicator up to a desired position,

35 deploying the connector by means of the applicator so as to connect the walls of the hollow structures.

The invention further includes a deforming instrument to reduce the dimensions of an annular member of a connector for mechanically connecting hollow structures into an oval

shape, in situ. This instrument is constructed like a forceps having two opposite pinching members to engage the outer side of the annular member and is provided with a stop to limit movement of the pinching members when applying a deforming  
5 force in the direction of the desired reduced dimension of the annular member.

The invention also includes a punch for punching out an anastomosis made by a connector having an annular member. Said punch comprises an expandable inner gripping means which  
10 is insertable in the connector. An outer cutting tube has a sharp punching edge adapted to fit closely to the connector. The inner diameter of the cutting tube is equal to or slightly larger than the largest diameter of the connector. The cutting tube is slidable with respect to the gripping means to punch  
15 out the anastomosis when the connector is held by the gripping means.

The invention will further be described with reference to the drawings showing embodiments of the invention by way of example.

20 Fig. 1 is a perspective view of an embodiment of the connector according to the invention.

Fig. 2 is a view of the connector of fig. 1 in radial direction.

25 Fig. 3 is a view of the connector of fig. 1 in axial direction.

Fig. 4 is a perspective view of an applicator for use with the connector of figs. 1-3, on a smaller scale.

Fig. 5 is a front view of the applicator of fig. 4.

30 Fig. 6 is a sectional view of the applicator of fig. 4, along the plane VI-VI in fig. 5.

Fig. 7 is an axial view of the outer member of the applicator of fig. 4, on a larger scale.

Fig. 8 is a sectional view of the outer member of fig. 7 along the plane VIII-VIII.

35 Fig. 9 is an axial view of the inner member of the applicator of fig. 4, on a larger scale.

Fig. 10 is a sectional view of the inner member of fig. 9, taken along the line X-X.



Fig. 11 is a very schematic perspective view of members forming the head of an alternative embodiment of the applicator according to the invention.

5 Fig. 12 is a sectional view along the line XII-XII in fig. 11.

Figs. 13A-13C are longitudinal sectional views of the applicator head of fig. 11, in three different positions during deployment of the connector.

10 Fig. 14 is a very schematic side view of an alternative embodiment of the connector according to the invention.

Fig. 15 is a very schematic side view of the head of an applicator for delivering and deploying the connector of Fig. 14.

15 Fig. 16 is a very schematic, partly cut-away side view of the head of a further embodiment of an applicator according to the invention.

Fig. 17 is an enlarged longitudinal sectional view of the head of an applicator which is slightly modified with respect to the applicator of Fig. 4 - 10.

20 Fig. 18 is an enlarged perspective view of the head of an expansion core for use in the applicator of Fig. 17.

Fig. 19 shows in an enlarged perspective view modified parts which may be used in the applicator of Fig. 17.

25 Fig. 20 is a side view of the head of the expansion core of Fig. 18, provided with an insertion cone.

Fig. 21 is a sectional view of a hollow structure and the head of the expansion core after insertion into the hollow structure.

30 Fig. 22 is a perspective view of two hollow structures to illustrate a phenomenon called seagulling.

Fig. 23 is a longitudinal sectional view of a deforming instrument for reducing the outer size of a connector for making an anastomosis.

35 fig. 24A and 24B are two longitudinal sectional views of a punch for punching out an anastomosis made by a connector.

Figs. 1-3 show an embodiment of a connector for mechanically connecting hollow structures, in particular small

blood vessels, such as coronary arteries. The connector is specially designed for making a side-to-side anastomosis but may also be used or adapted to make other connections, for example an end-to-side anastomoses or other joints.

5           The connector as shown comprises an annular member 1 and a plurality of joining means in the form of staple-like elements 2 spaced around the circumference of the annular member 1. The annular member and staple-like elements are preferably formed from one piece of material, preferably metal  
10 such as stainless steel 316L or titanium.

          The annular member as shown in figs. 1-3 comprises a continuous elongated element having a sinusoidal pattern meandering about a circle line through the annular member. The alternating waves 3 and 4 of the pattern have a different wave  
15 length in order to accommodate the staple-like elements 2 which are formed at each wave 4, at the apex thereof. The meandering pattern of the annular member 1 creates the expandability of the annular member by widening the meanders or waves of the  
20 1. The deformation of the annular member 1 is plastically, so that the annular member 1 will retain its shape after expansion.

          The configuration of the annular member 1 may vary within a broad range, including the length of the annular  
25 member 1. The term annular also covers tubular members.

          The staple-like elements 2 comprise two staple portions 5, 6 which extend from the point of attachment to the annular member 1 in opposite directions. In the embodiment shown, both staple portions 5, 6 are aligned and are  
30 substantially each other's mirror image, but it should be kept in mind that that need not be the case. Instead thereof, the length, thickness and slope towards the free ends of the staple portions 5,6 can be varied to accommodate required bending characteristics or vessel wall thicknesses.

35           As is shown in figs. 1-3, in which the connector is shown in its starting position in which it is delivered to the anastomosis site, the staple-like elements are substantially straight and extend parallel to the center axis of the annular

member. The staple portions 5, 6 are slightly tapered towards their free ends, both in radial thickness and in circumferential width. The tapering is on the outer side of the staple portions 5, 6, whereas the radial inner side of the staple portions 5, 6 extends parallel to the center axis. The circumferential sides of the staple portions 5, 6 are inclined relative to a radial plane through the center of the staple portions 5, 6 such that the width of a staple-like element 2 is smaller on the radial inner side than on the radial outer side. If desired, the extreme tips of the staple portions 5, 6 may be preformed into the anticipated curve, to increase the predictability of the deformation of the staple portions 5, 6. The waves 3 may also be slightly tapered, i.e. having a diminishing thickness in axial direction in the same manner as the adjacent staple portions 5.

Figs. 4-10 show an embodiment of the applicator according to the invention. The applicator includes a main body 7, a grip 8 extending downwardly therefrom on the rear end, a control lever 9 pivotally connected to the front end of the main body 7 and extending downwardly, and a stroke limiter 10 pivotally attached to the lower end of the control lever 9 and slidably connected to the lower end of the grip 8. A pin slot connection 11 between the stroke limiter 10 and the grip 8 determines the maximum stroke of the control lever 10. The control arm may be locked in position by locking the stroke limiter 10 to the grip 8. The control lever 9 is pivotally connected to an intermediate pivot 12 in order to provide a long lever arm 13 and a short lever arm 14. The end of the short lever arm 14 is pivotally connected to a sliding block 15, the sliding motion being guided and limited through a bolt 16.

Attached to the sliding block 15 is an outer tube member 17 and attached to the main body 7 is an inner tube member 18. The inner and outer members 17, 18 together form a shank-like element and on the free end thereof a head 20 adapted to accommodate a connector in order to deliver it to the anastomosis site and to deploy it into a joining position. Figs. 7 and 8/8a show the outer tube member 17 and figs. 9 and

10/10a show the inner tube member 18 in more detail. Inside of the inner tube member is an expansion core connected to an expansion control means 22.

5 The outer member 17 is provided on its distal end with proximal anvil formations or anvils 23 having a curved surface 24 facing, in a assembled condition, corresponding curved surfaces 25 of distal anvil formations or anvils 26 provided on the distal end of the inner member 18. The number of distal and proximal anvils 23, 26 is equal to the number of staple-like  
10 elements 2 of each connector, in this case 8. The anvils 23, 26 are distributed around the circumference of the inner and outer members 17, 18 in the same manner as the staple-like elements on the connector, in this case equally spaced around the circumference. The inner member 18 is provided with a seat 27,  
15 proximal of the anvils 26, to accommodate the connector during delivery and in this starting position of the applicator and connector, the inner and outer members 17, 18 have such relative position that the connector is positioned between adjacent anvils 23 and 26 of the inner and outer members 17,  
20 18, with each staple-like element 2 being aligned with respective anvils 23, 26.

In order to be able to expand the connector which is seated on the seat 27 of the inner member 18, this inner member is slitted with cuts or slits 28 extending from the distal end  
25 of the inner member 18 a distance in proximal direction. The length of the slits is such that the tongues left between the slits 28 may undergo a sufficient radial deflection to expand the connector to a sufficient extent. The length of the slits may for example be 5-10 times the diameter of the inner member  
30 18. The lumen 29 through the inner tube member 18 has a flaired end part 30, in which the diameter of the lumen is increased in distal direction, for example at an angle of 30° to 45°. This end part 30 is adapted to accommodate the tapered end part of the expansion core 21, so that when the expansion core 21 is  
35 retracted in proximal direction by the expansion control means 22, the tapered end part urges the tongues between the slits 28 of the inner tube member 18 outwardly so that the connector present on the seat 27 is expanded.

As is shown in figures 7 and 8, also the outer tube member 17 is slitted. The outer tube member 18 comprises first slits 31 extending from the distal end of the outer tube member 17 a distance in proximal direction, and partly overlapping second slits 32 which alternate with the first slits 31 and extend from a position intermediate the ends of the first slits 31 to a position proximal of the first slits 31. The total length of the first and second slits may for example be 5-10 times the diameter of the outer member 18. Due to this slit arrangement, the radial and tangential strength of the outer member 17 is increased.

The operation of the applicator and connector as shown and described before is as follows.

The shank-like element 19 with a connector positioned on the seat 27 of the head 20 is inserted into one of the vessels to be joined and is delivered to the site where the anastomosis should be accomplished. The control lever 9 is in the position as shown in fig. 4. If the head 20 and therefore the connector is positioned correctly with respect to vessel walls which are positioned around the connector, the expansion control means 22 is actuated to retract the expansion core 21 so as to expand the inner member 18 and therefore the annular member 1 of the connector. Since the outer tube member 17 is also slitted, it is possible for the outer member 17 to follow the expansion of the inner member. As a result the anvil formations 23 and 26 remain substantially in their relative opposite positions, so that, after expansion of the annular member 1 of the connector, it is possible to activate the anvils 23, 26 in order to deform the staple-like elements 2 of the connector.

The activation of the anvils 23, 26 is effected by sliding the outer tube member 17 in distal direction along the inner member 18 so as to bring the opposite anvils 23, 26 closer to each other thereby engaging the initially straight staple portions 5, 6 of the staple-like elements 2 and upon a further approaching movement of anvils 23, 26 the staple portions 5, 6 follow the curvature of the curved surfaces 24, 25 of the anvils 23, 26. The curved surfaces 24, 25 are shaped

as circular segments, which extend through approximately 91-120°, and preferably 115°, which is sufficient to allow a full deformation of each staple portion 5, 6. Depending on the lateral and radial curvature of the surfaces 24, 25, staple portions 5, 6 are deformed either to a C-shape to form a perfect or overlapping circle, or to a B-shape or an overlapping B-shape. After both the annular member 1 and the staple-like elements 2 are deformed into their joining position, the staple portions 5, 6 clamp the vessel walls of adjacent vessels between each other thereby effecting an anastomosis. The expansion core 21 can then be moved back to the starting position so that both the inner and outer members are collapsed into their unexpanded condition in which the outer dimensions of the distal anvil formations 26 is smaller than the inner dimension of the annular member 1 of the connector in expanded condition, so that the applicator can be withdrawn from within the annular member 1 of the connector so as to be removed from the vessel and the body of the patient.

Figures 11-13 show an alternative embodiment of an applicator according to the invention, which may be used to deliver and deploy the connector of figs. 1-3. Figures 11-13 show a head 120 of the shank-like element of the applicator, said head being formed by an outer member 117 and an inner member 118. The inner member has a seat 127 and distal anvils 126. The outer member 17 has proximal anvils 123 between each two adjacent anvils 123. There is created a gap 133 of sufficient axial length to accommodate wedges 134 and provided on the distal end of an expansion member 135. The expansion member 135 fits slidably around the outer member 117 such that the wedges are positioned in their respective gap 133 between adjacent anvils 23 or distally thereof. The wedges 134 extend inwardly from the tube-like expansion member 135 up to the outer diameter of the inner member 118, so that the extreme tips of the wedges 134 engage the outer surface of the inner member 118. The extreme tips of the wedges 134 are sharp so as to facilitate them to slide underneath the annular member 1 so as to engage the annular member 1 and upon a distal sliding movement of the expansion member 135 relative to the inner and

outer members 117, 118, the annular member 1 of the connector 1 is expanded by the wedges 134.

In this embodiment, the deformation of the staple-like elements 2 take place before the expansion of the annular member 1, so that the inner and outer members 117, 118 are actuated first in order to close the staple-like elements 2 (Fig. 13a-13b), whereafter the expansion member 135 is moved in distal direction so as to expand the annular member 1 and urge it over the anvil formations 126 so as to remove the connector from the head 120 of the applicator (Fig. 13c).

Fig. 14 shows an alternative embodiment of a connector for connecting the walls of hollow structures, in particular small vessels through an anastomosis. The connector includes an annular member 201 having staple-like elements 202. The annular member 201 and staple-like elements 202 are very similar to those of the embodiment of fig. 1, with the exception of one aspect. The connector has a center line C which is in the center of the lumen through the connector. The connector also includes a main plane M which extends through the middle of the annular member. In this embodiment, the center line C is at an angle to the main plane M, which is different from 90°. In the present case, the angle within the plane of the drawing is circa 45°. The staple-like elements 202 extend parallel to the center line C.

The reason for using this embodiment is as follows. The maximum size (orifice area) of the anastomosis is limited by the size of the connector and applicator, which in turn is limited by the diameter of the vessel through which the applicator and connector are inserted. In order to increase the orifice area of the anastomosis, the plane of stapling can be tilted, for example 45°. After expansion to the joining position, this results in an elliptical anastomosis with an increased orifice area (in this case  $\square 2 = 1.41$ ) as compared to a circular anastomosis, whereas the size of the applicator remains unchanged. Thus, it is possible to create bigger anastomoses through a blood vessel having a particular size.

In practice, the staple-like elements 202 of the connector will remain parallel to the central axis of the

applicator, while the meandering ring will extend at an angle of 45° to a plane which is perpendicular to the center line C. The meandering waves 203, 204 are, however, within the circular cylinder around the center line C.

5            Fig. 15 shows a head 220 of an applicator to deliver and deploy the connector according to Fig. 14. As is shown, the position of the proximal and distal anvil formations 223, 226 are adapted to the relative position of the staple-like elements 202.

10           Fig. 16 shows a further embodiment of an applicator for making anastomoses. In anastomosis procedures, it is often desirable to punch out a hole in the vessel wall at the site of the anticipated anastomosis. This is especially the case when doing the proximal anastomosis in CABG (coronary artery bypass grafting) operations, where for example a piece of saphenous vein graft has to be connected to the ascending aorta, which is 15 a big (30 mm) artery and has a significant wall thickness (2-3 mm). However, on a much more delicate scale, punching out a small hole for the distal anastomosis on the coronary artery itself could also prove to be advantageous.

20           The embodiment of the applicator according to fig. 16 has means to punch out a hole in the vessel wall incorporated in the head thereof. Fig. 16 shows that the head of this embodiment includes an anastomosis portion 336 and a punching 25 portion 337. This punching portion 337 is positioned distally of the anastomoses portion 336. The punching portion 337 includes two relatively movable parts, a distal part 338 and a proximal part 339. The distal part 338 is mounted on a core 340 running through the head and shank and is adapted to be 30 operated in order to move axially with respect to the proximal part 339. On their sides facing each other, both parts 338 and 339 are provided with cutting means, including a circular knife 341 on the proximal portion 339 and a counter edge 342. The circular knife 341 is sized to accurately slide over the distal 35 part 338 while performing a cutting action in co-operation with the edge 342. The distal front of the distal part 338 is rounded for easy insertion into an arteriotomy. Alternatively, this rounded front can be replaced by a knife or a conical



shape, ending in a sharp point. This configuration permits creating an arteriotomy, punching out a hole and securing the anastomosis with one instrument and requiring only one instrument insertion. To punch the hole this rounded front of the distal part 338 is inserted into the arteriotomy, subsequently this distal part 338 is pulled against the circular knife 341 of the proximal part 339. A circular piece of vessel wall is then cut out and remains trapped between and inside the distal and proximal parts 338, 339 which together enclose this vessel wall piece. This entrapment is important since loose tissue fragments can embolize.

Subsequently, the applicator is pushed further inwardly so that the anastomosis portion 336 is brought in line with the vessel walls to be joined. The expansion mechanism of the anastomosis portion 336 is activated by further retracting the core 340 and distal part 338 in order to push the expansion core 321 (formed on the proximal part 339) in proximal direction with respect to the anastomosis portion 336 so as to expand the seat 327 where the connector is positioned. The further operation of the applicator is similar to that of the embodiment of Figs. 4-10.

This embodiment has the unique feature of being capable to punch a hole and secure the anastomosis during one instrument insertion. Because it is not necessary to remove the applicator between these two manipulations, there is very limited blood loss and maximum control. This makes the applicator very suitable for making proximal anastomoses on the aorta in port access CABG.

Alternatively, the punch mechanism could be replaced by a single, linear knife, which makes a linear arteriotomy. The applicator is then advanced through this arteriotomy and deforms it to a more circular shape.

The punch mechanism could also be replaced by a simple, circular knife. A pointed wire with a simple retaining mechanism like a hook, extending distally to the circular knife would puncture the vessel wall before cutting and would hold the piece of vessel wall after cutting to prevent it from embolizing in the patient. The punch or cut mechanisms could

also be combined with an applicator that is constructed as a balloon-type expanding device.

Figs. 17 - show some further refinements which may be incorporated in the applicator of Fig. 10.

5 In Fig. 17 it is shown that the outer member 17 is conically shaped towards the proximal anvil formations 23 on its distal end. This conical shape may be advantageous in case the resulting anastomosis has to be of approximately the same diameter as the diameter of the donor vessel (through which  
10 free end the connector is inserted). While at the site of the anastomosis there is enough room to accomodate the anvils after expansion, the diameter of the vessel is limiting the amount of expansion. The conical shape helps to maximize the amount of expansion that is possible without injuring the vessel wall.

15 Fig. 18 and 19 show improvements relating to the inner member 18 of the applicator. In order to predictably bend the staple-like joining means, the anvils 23, 26 have to be kept perfectly aligned. While material stiffness and design may suffice, in some cases guidance of especially the relatively  
20 thin legs with their distal anvils 26, resulting from the slits 28 in the inner member 18, may be of benefit. This can be done in three ways:

Fig. 18 shows that there are provided triangular protrusions 50 on a slightly extended, cylindrical part 51 of  
25 central expansion core 21. During expansion, the distal ends of the legs of inner member 18 are caught between the widely open bases of triangular recessions 52, and are guided to their exact location by the progressive narrowing of these recessions, as the inner member 18 advances. Thus the  
30 triangular protrusions 50/recessions 52 act as guide members for the legs of the inner member carrying the distal anvils 26.

Not shown are radial slits on the conical surface of central expansion core 21 and small protrusions on the distal ends of slitted inner member 18, that fit into the slits in  
35 core 21.

According to Fig. 19 there are provided U-shaped pieces 53 that fit around the legs, formed by the slits 31 in outer member 17, behind the proximal anvils 23. The two

radially pointing arms 54 of the U-shaped piece 53 have sufficient length to also embrace the legs of inner member 18. The U-shaped pieces 53 may be attached to an expandable ring or tubular element, like a meandering ring, to result in a single  
5 piece that provides guidance for keeping the proximal and distal anvils aligned.

In Fig. 20 and 21 it is shown that, for easy insertion, a separate nose 55 cone may be provided that is pivotally connected to the central expansion core 21 (Fig 20).  
10 This can be achieved by connecting the nose cone 55 with a flexible thread or wire 56 to central expansion core 21. This results in an articulation of the nose-cone that is necessary to enable a position of 90° relative to the axis of the acceptor vessel during expansion and stapling of the anastomosis (Fig.  
15 21). Introduction may be done at 45°.

For proper introduction of the distal anvils 26 in the target vessel, optimal visualisation is necessary. In order to achieve this, the previously mounted donor vessel may be moved temporarily over the proximal anvils 23 to a location somewhere  
20 on the tapered end of outer member 17. With an unobstructed view, the connector then can be introduced into the target vessel. Once satisfied with the position, the donor vessel can be slid back to a position between the proximal and distal vessels, followed by expansion and closure of the joining  
25 means.

In the treatment of obstructive coronary artery disease, the connection between newly grafted donor vessels and the coronary artery downstream of its stenosis, where it is unobstructed again, should offer no obstruction to the  
30 bloodflow. In order to achieve this in the disclosed method, it is advantageous to construct anastomoses with an orifice area that is larger than the target vessel. In practice, the coronary artery, which is the target vessel is most often smaller than the donor vessel. In case of a circular or  
35 polygonal anastomosis, the construction of such an anastomosis is only achieved if the diameter of the anastomosis exceeds the transverse diameter of the target vessel. This oversizing of the anastomosis, while attractive with respect to the objective

of unobstructed bloodflow, may lead to a phenomenon called seagulling, if overdone. This phenomenon is illustrated in Fig. 22. This seagulling is characterized by a dimple D in the vessel wall, which may lead to flow obstruction. When this happens, one way to counteract it is to deform the annular member of the connector from circular to oval after completion of the anastomosis. The orientation of the resulting oval shape should be so that the longer axis is perfectly aligned longitudinally with the smallest vessel, which in most cases will be the target or coronary vessel. A special instrument is needed in order to be able to apply exactly the right amount of deformation, since exaggeration of the oval shape may lead to an unacceptable decrease in anastomotic orifice area. One such deforming instrument 57 is shown in Fig. 23. It may be constructed like a forceps with a specifically sized metal protrusion 58, which acts like a stop when applying the deforming force in the direction of the desired reduced anastomotic diameter.

While the correct application of the connector should result in a satisfactory anastomosis in the vast majority of cases, it should be possible to remove the connector if necessary. For example, major blood leakage due to faulty tissue capture between the tips of the staple-like joining means, or incorrect orientation of the donor vessel could prompt the surgeon to consider undoing the anastomosis. This should be done with as little damage to the acceptor (coronary) vessel as possible. The amount of damage to the donor vessel is less important, because generally some excess vessel material is harvested and allows cutting off the damaged segment. One way of removing the applied connector is to open the tips of the joining means one by one with fine forceps. This can be a very delicate job due to the small size of the connector, and may be time consuming. The result would at the very best be a nearly undamaged coronary vessel, albeit with a row of small holes near the edges of the arteriotomy.

An alternative approach, that would also be applicable in case of port-access surgery is to cut out the connector, including a very small rim of vessel wall that is captured

between the joining means, with a very sharp, modified punch 59 as shown in Fig. 24A and 24B. This also offers fresh, cleanly cut edges of the arteriotomy for a second try, if desired. The modified punch has an expandable gripping means 60 with small distal notches 61, which is inserted in the connector 1, after the donor vessel is longitudinally cut open. This expandable gripping means 60 can be realized by providing longitudinal slits in an inner member, much in the same way as in the applicator. Expansion is effected by pulling a conical core 62 element inside (Fig. 24B). This expansion establishes a firm hold and centers the connector 1 in front of an outer cutting tube 63, which has a very sharp edge 64. The cutting tube 63 has an inner diameter which is equal to or slightly larger than the largest diameter of the connector 1, including its joining means. The cutting tube 63 is then moved into the anastomosis and the complete anastomosis is punched out and removed when the punch is withdrawn. The cutting tube 63 can be circular, or polygonal in order to fit the connector 1 as closely as possible. In case of a circular shape, the cutting tube 63 may be rotated relatively to the inner member 60 holding the connector 1 and tissue, in order to improve the cutting effect of the sharp edge 64.

From the foregoing it is clear that the present invention provides a connector, applicator and method for mechanically connecting small blood vessels and the like in a simple, reliable and efficient manner.

The invention is not restricted to the embodiments shown in the drawing and described herein before and can be varied within the scope of the accompanying claims.

## CLAIMS

1. A connector for mechanically connecting hollow structures, in particular small vessels, comprising:

an annular member of deformable material, said member having a center line and a main plane, and being adapted to be permanently deformed by expansion from a first size in a starting position in which it is delivered to a desired anastomosis site, to a second, larger size in a joining position in which it connects the hollow structures,

circumferentially spaced means for joining abutting walls of the hollow structures together, said means including staple-like elements being adapted to be permanently deformed from a starting position in which the connector is delivered to a desired site, to a joining position in which they engage the hollow structures to connect them, said staple-like elements having at least two free ends and being attached to the annular member between its free ends and being tapered from the annular member towards their free ends.

2. The connector as claimed in claim 1, wherein at least the radial thickness of the staple-like elements is diminished towards the respective free ends.

3. The connector as claimed in claim 1 or 2, wherein a center line of each of the staple-like elements is disposed substantially within a radial plane of the annular member.

4. The connector as claimed in claim 2, wherein the staple-like elements are substantially straight in their starting position.

5. The connector as claimed in claim 3, wherein the staple-like elements have extreme tips which are preformed into the anticipated curve of the deformation to the joining position.

6. The connector as claimed in one of the preceding claims, wherein the connector is made from one piece of material.

7. The connector as claimed in one of the preceding

claims, wherein parts of the staple-like elements on opposite sides of their point of attachment to the annular member are configured differently.

5 8. The connector as claimed in one of the preceding claims, wherein the annular member is made up from a continuous elongated piece of material having a sinusoidal pattern meandering about a circumferential line through the main plane of the annular member.

10 9. The connector as claimed in claim 8, wherein the staple-like elements are formed at an apex of the sinusoidal pattern.

10. The connector as claimed in one of the preceding claims, wherein the main plane is at an angle to the center line of the annular member different from  $90^{\circ}$ .

15 11. An applicator for delivering and deploying a connector for mechanically connecting hollow structures, said connector including an expandable annular member and a plurality of deformable staple-like elements spaced around the circumference of the annular member, comprising:

20 a shank-like element;  
a head formed at a distal end of the shank-like element, said head being adjustable in such a manner that the annular member and the staple-like elements of the connector are deformed from the starting position to the joining position  
25 when said adjusting takes place,

said head including an inner member and an outer member which are longitudinally slidable and include longitudinally opposite anvil formations which are movable to and from upon relative sliding movements of the inner and outer  
30 members in order to deform the staple-like elements to their joining position;

wherein both the inner and outer members are expandable to deform the connector to the joining position.

35 12. The applicator as claimed in claim 11, wherein both the inner member and the outer member is slitted in axial direction to allow expansion.

13. The applicator as claimed in claim 12, wherein the outer member includes at least first slits and second

slits, said first slits are arranged at an end of the outer member which forms part of the head and extends between the anvil formations, said second slits being spaced from said end of the outer member, and alternate with the first slits and are  
5 configured in overlapping arrangement.

14. The applicator as claimed in claim 12, adapted to expand the annular member and deform the staple-like elements in two steps, wherein the inner member is hollow and the applicator further comprises a tapered core member which is  
10 slidable through the inner member and is operatively connected to a control means to slide the core member into and out of the head to expand the inner and outer members.

15. The applicator as claimed in claim 14, wherein the core member and control means are used to control the  
15 relative movements of the inner and outer members as well.

16. The applicator as claimed in claim 11, wherein the anvil formations, on their sides facing each other, have curved surfaces dictating the deformation of the staple-like elements, said curved surfaces are formed to such an extent  
20 that they terminate at an angle to the longitudinal axis of the head which is slightly beyond  $90^{\circ}$ , for example  $91^{\circ}$ - $120^{\circ}$ .

17. The applicator as claimed in claim 16, wherein the curved surface is shaped as a circular segment which is  
25 slightly larger than  $90^{\circ}$ .

18. The applicator as claimed in claim 11, including a grip for handling the applicator, said grip being attached to the proximal end of the shank-like element and including the control means for actuating at least the inner and outer  
members.

19. An applicator for delivering and deploying a connector for mechanically connecting hollow structures, said connector including an expandable annular member and a plurality of deformable staple-like elements spaced around the circumference of the annular member, comprising:  
30

35 a shank-like element;  
a head formed at a distal end of the shank-like element, said head being adjustable in such a manner that the annular member and the staple-like elements of the connector



are deformed from the starting position to the joining position when said adjusting takes place,

said head including an inner member and an outer member which are longitudinally slidable and include

5 longitudinally opposite anvil formations which are movable to and for upon relative sliding movements of the inner and outer members in order to deform the staple-like elements to their joining position;

said head further including an expansion member  
10 comprising wedges adapted to slide underneath the annular member.

20. The applicator as claimed in claim 19, wherein the expansion member is slidable relative to the inner and outer members.

15 21. The applicator as claimed in claim 20, wherein the wedges are interleaved with the anvil formations.

22. The applicator as claimed in claim 20, wherein the inner member is adapted to support the annular member in its starting position.

20 23. The applicator as claimed in claim 20, further including control means adapted to first actuate the inner and outer member to deform the staple-like elements to the joining position, and then to actuate the expansion member in order to expand the annular member to the joining position.

25 24. The applicator as claimed in claim 20, wherein the anvil formations on the inner member have an outer dimension which is smaller than the maximum outer dimension of the expansion member, such that the connector can be removed from the applicator in the distal direction over the anvil  
30 formations on the inner member.

25. The applicator as claimed in claim 22, wherein the expansion member includes a tube-like member arranged around the outer member, said tube-like member having the wedges attached to its distal end, said wedges extending  
35 inwardly to the outer surface of the inner member.

26. The applicator as claimed in claim 25, wherein the outer member has indentations between the proximal anvil formations to accommodate the wedges in a starting position.

thereof.

27. The applicator as claimed in claim 11 or 19, wherein the shank-like element is rigid.

5 28. The applicator as claimed in claim 11 or 19, wherein the shank-like element is flexible.

29. An applicator for delivering and deploying a connector for mechanically connecting hollow structures, said connector including an expandable annular member and a plurality of deformable joining elements spaced around the circumference of the annular member, comprising:

a shank-like element;

a head formed at a distal end of the shank-like element, said head including an anastomosis portion which is adjustable in such a manner that the annular member and the joining elements of the connector are deformed from the starting position to the joining position when said adjusting takes place, said head further including a punching portion distally of the anastomosis portion and including two relatively movable parts configured to cause a punching action on a wall of the hollow structure and to catch a punched-out part of said wall.

30. The applicator as claimed in claim 29, wherein the two parts of the punching portion are axially movable and include a distal part shaped to be inserted into an arteriotomy of the hollow structure, and a proximal part, said distal and proximal parts including cooperating knife members facing each other and adapted to catch the punched-out part between said distal and proximal parts.

31. The applicator as claimed in claim 30, wherein the anastomosis portion and the puncture portion are supported by a core member extending through the head of the applicator.

32. The applicator as claimed in claim 29, wherein a distal front of the punching portion of the head comprises cutting means to cut an arteriotomy in one of the hollow structures.

33. A method of delivering and deploying a connector for mechanically connecting hollow structures, said method comprising the steps of:

providing a connector for joining adjacent walls of the hollow structures,

providing an applicator for said connector, said applicator including cutting means,

5 making an arteriotomy in the wall of one of the hollow structures,

inserting the cutting means of the applicator partly into said one of the hollow structures through the arteriotomy, so as to cut a hole in the wall,

10 advancing the applicator up to a desired position,

deploying the connector by means of the applicator so as to connect the walls of the hollow structures.

34. The method as claimed in claim 32, wherein the arteriotomy is made by a second cutting means provided on a distal front of the applicator.

35. An applicator for delivering and deploying a connector for mechanically connecting hollow structures, said connector including an expandable annular member and a plurality of deformable joining elements spaced around the circumference of the annular member, comprising:

a shank-like element; and

a head formed at a distal end of the shank-like element, said head including an anastomosis portion which is adjustable in such a manner that the annular member and the joining elements of the connector are deformed from the starting position to the joining position when said adjusting takes place, said head having a distal front which comprises cutting means to cut an arteriotomy in one of the hollow structures.

30 36. A connector for mechanically connecting hollow structures, in particular small vessels, comprising:

an annular member of deformable material, said member having a center line and a main plane, and being adapted to be permanently deformed by expansion from a first size in a starting position in which it is delivered to a desired anastomosis site, to a second, larger size in a joining position in which it connects the hollow structures, circumferentially spaced means for joining abutting

walls of the hollow structures together, said means including staple-like elements being adapted to be permanently deformed from a starting position in which the connector is delivered to a desired site, to a joining position in which they engage the hollow structures to connect them,

wherein the main plane through the annular member and the center line thereof are at an angle to each other.

37. A connector for mechanically connecting hollow structures, in particular small vessels, comprising:

an annular or tubular member of deformable material, said member being adapted to be permanently deformed from a first size in a starting position in which it is delivered to a desired site, to a second, larger size in a joining position in which it connects the hollow structures,

circumferentially spaced means for joining abutting walls of the hollow structures together, said means including staple-like elements being adapted to be permanently deformed from a starting position in which the connector is delivered to a desired site, to a joining position in which they engage the hollow structures to connect them, said staple-like elements being attached to the annular member near their center and extend in a direction parallel to the center line of the annular member.

38. The applicator as claimed in claim 11, wherein the outer surface of the outer member is slightly tapering towards the anvil formations thereof.

39. The applicator as claimed in claim 14, wherein the core member has guide members to guide parts of the inner members carrying the anvil formations during expansion.

40. The applicator as claimed in claim 14, wherein the applicator comprises U-shaped members that fit radially around axial legs formed in the outer member by axial slits, said U-shaped members being positioned proximally of the anvil formations on the outer member.

41. The applicator as claimed in claim 14, wherein the core member comprises a separate nose cone that is pivotally connected thereto, for example with a flexible thread or wire.

42. System for for mechanically connecting hollow structures, in particular small blood vessels, including the applicator of claim 11, and a connector including an expandable annular member and a plurality of deformable staple-like elements spaced around the circumference of the annular member, wherein the outer diameter of the anvil formations of the inner member in the unexpanded state is smaller than the inner diameter of the annular member of the connector in expanded state.

43. Deforming instrument to reduce the dimensions of an annular member of a connector for mechanically connecting hollow structures into an oval shape, constructed like a forceps having two opposite pinching members to engage the outer side of the annular member and being provided with a stop to limit movement of the pinching members when applying a deforming force in the direction of the desired reduced dimension of the annular member.

44. A punch for punching out an anastomosis made by a connector having an annular member, said punch comprising an expandable inner gripping means which is insertable in the connector, and an outer cutting tube having a sharp punching edge adapted to fit closely to the connector, said cutting tube having an inner diameter which is equal to or slightly larger than the largest diameter of the connector, and being slidable with respect to the gripping means to punch out the anastomosis when the connector is held by the gripping means.

45. Method of removing an anastomosis in hollow structures made by a connector having an annular member, comprising the steps of inserting a punch to the location of the anastomosis, gripping the annular member from the inside, moving a cutting tube towards the connector and allowing a sharp punching edge thereof to punch a hole into the hollow structure, whereafter the punch is withdrawn.

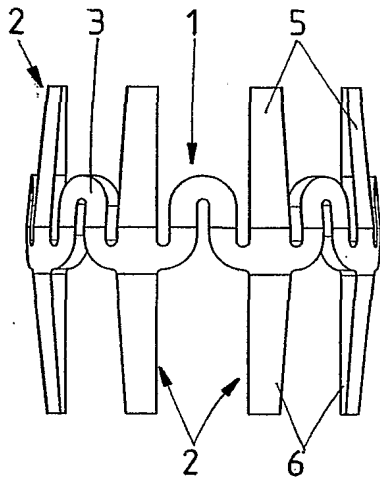

fig. 2

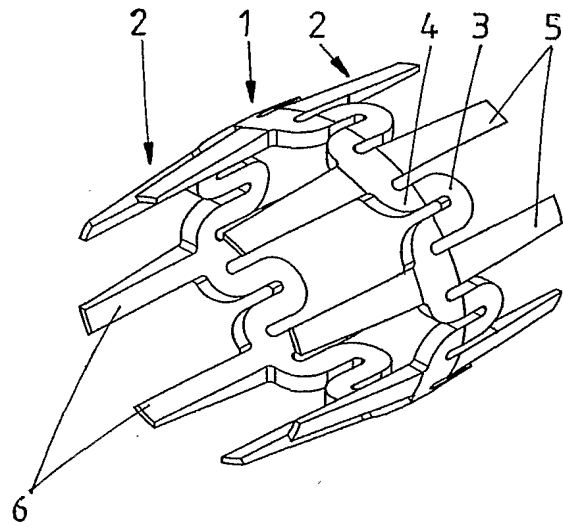

fig. 1

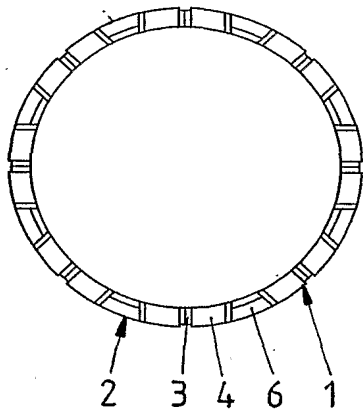

fig. 3

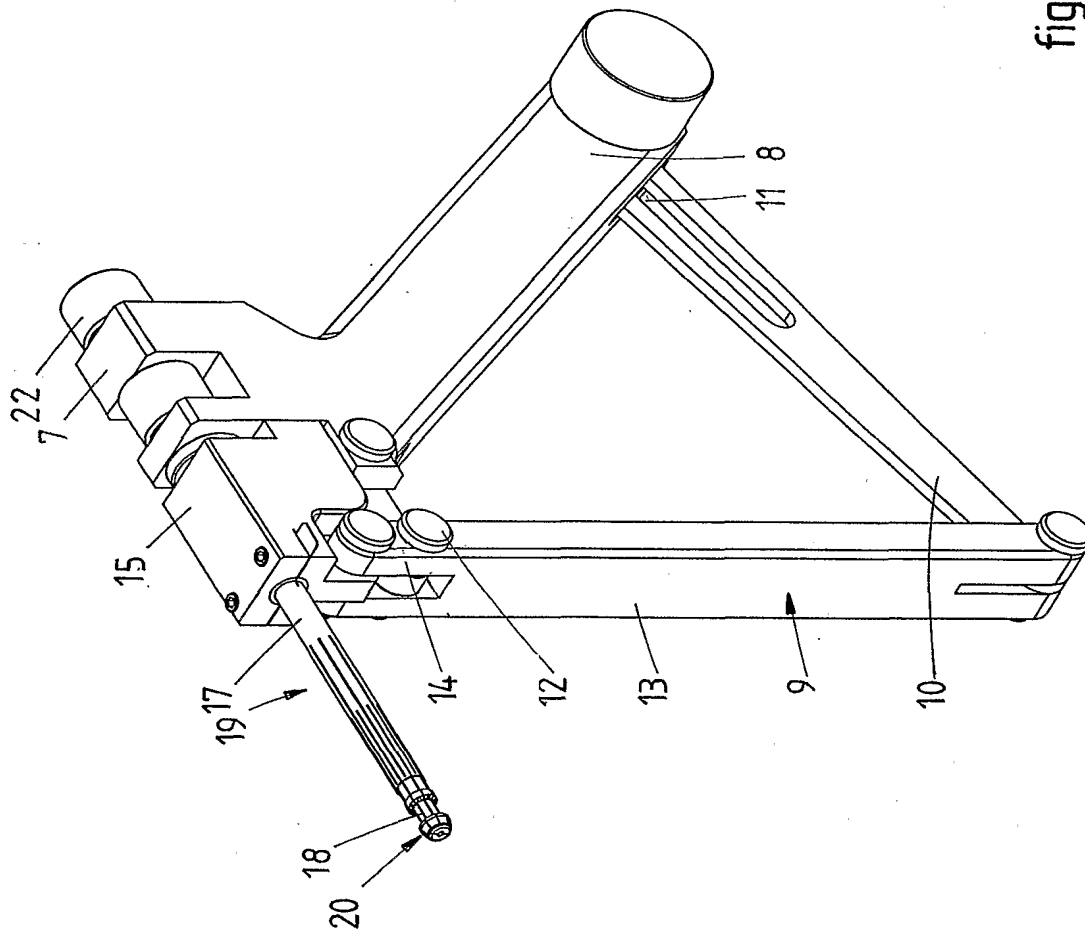

fig.4

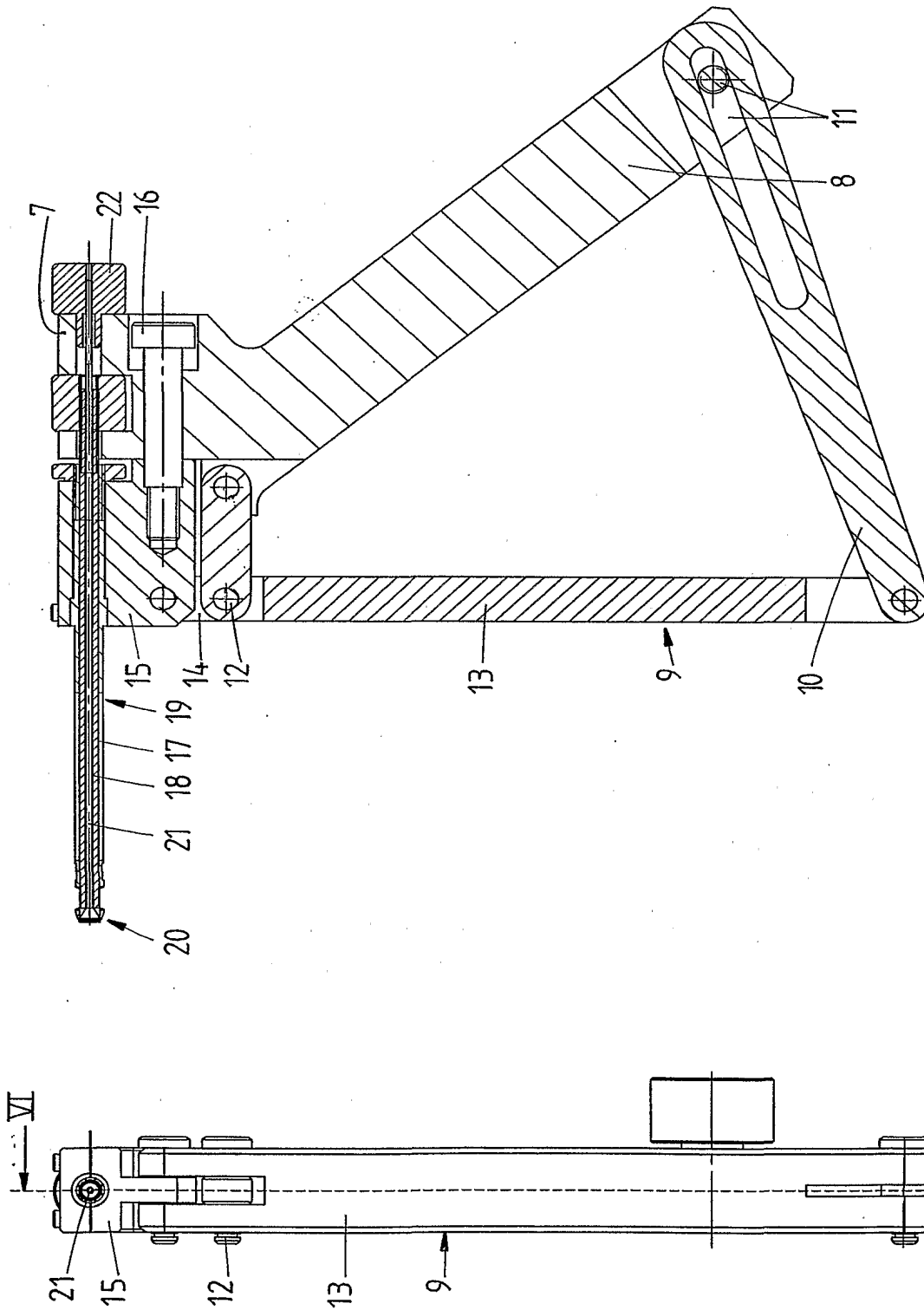

fig.6

fig.5



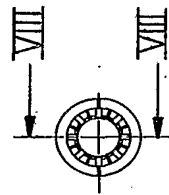
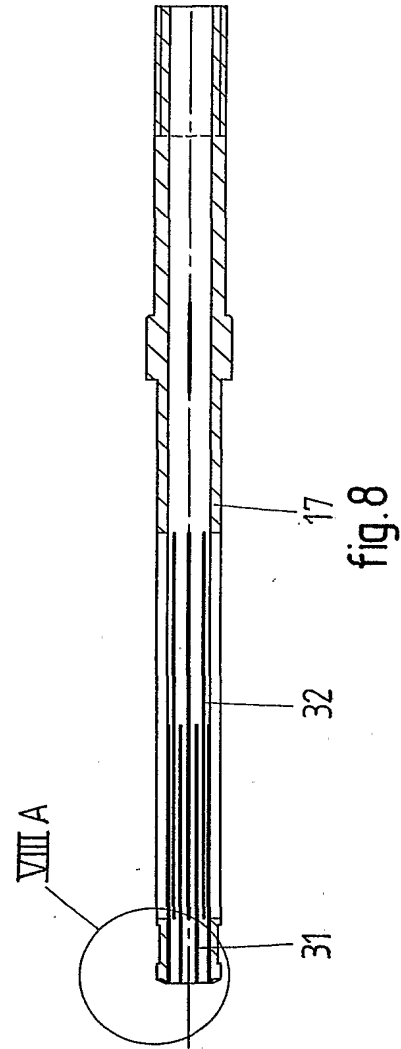
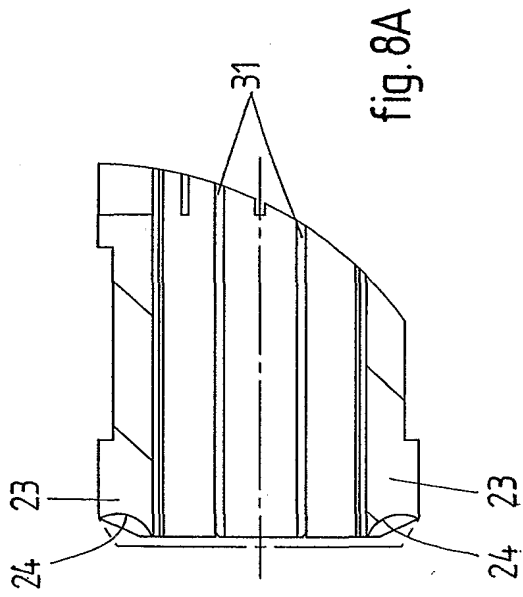

fig. 7

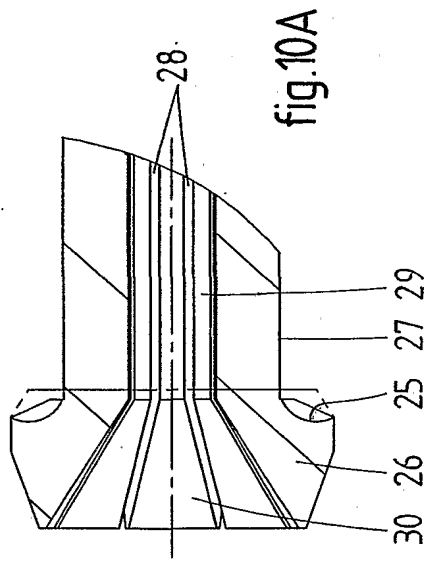

fig.10A

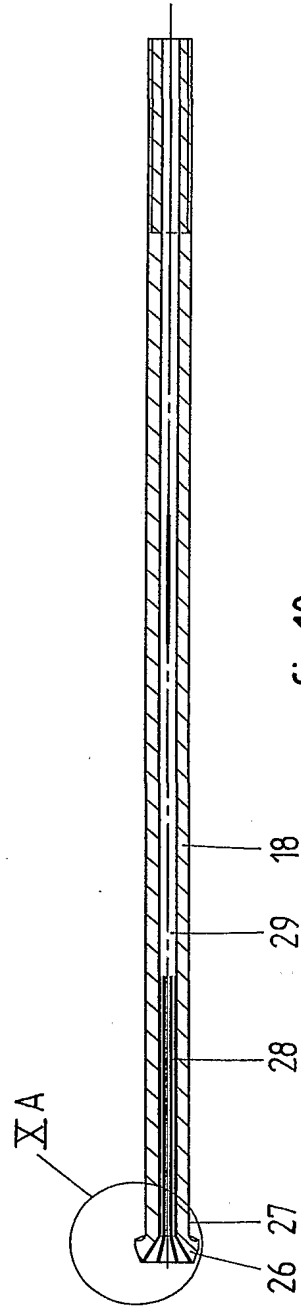

fig.10

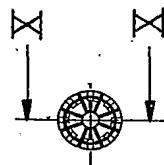

fig.9

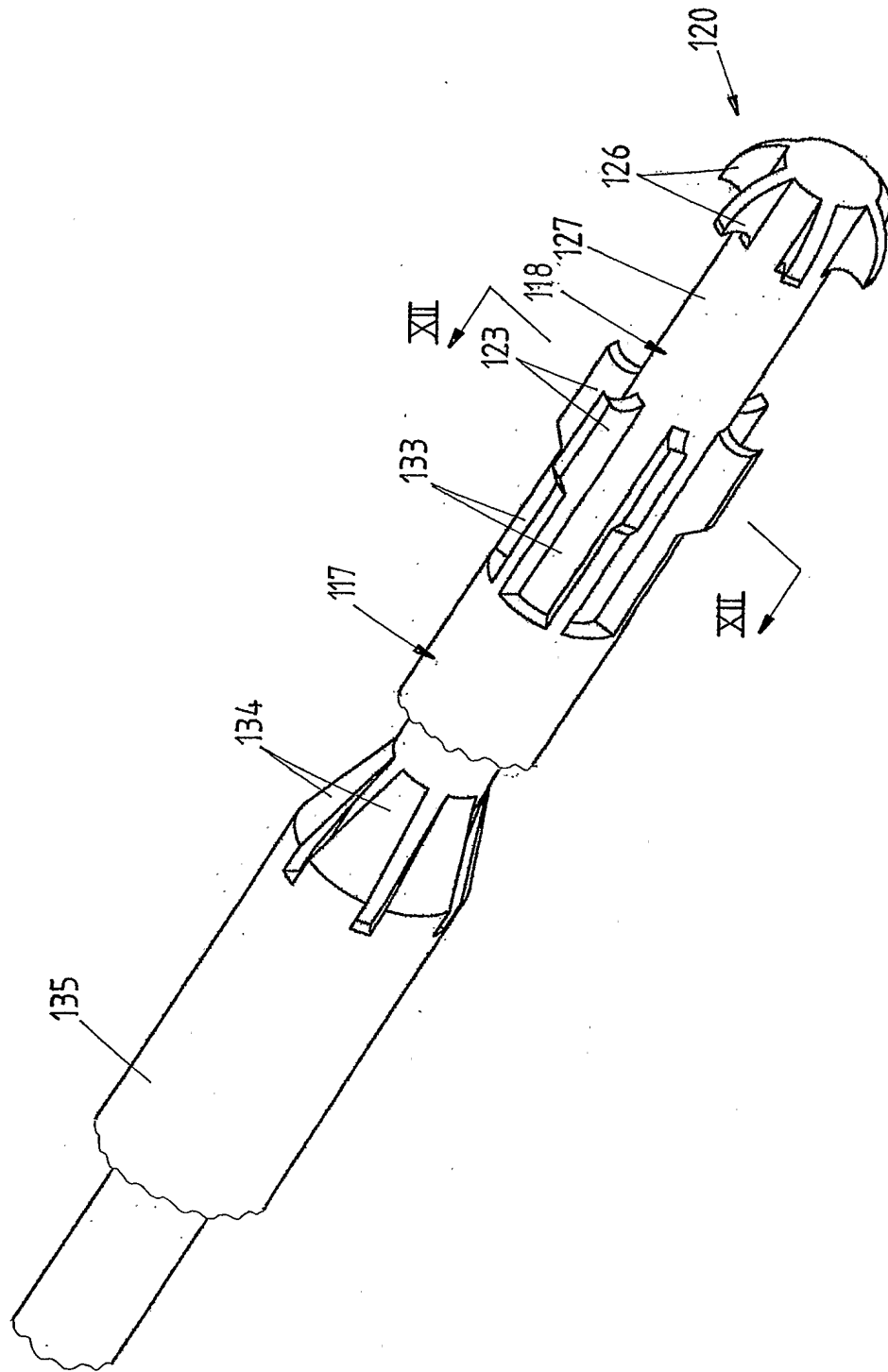

fig.11

7/13

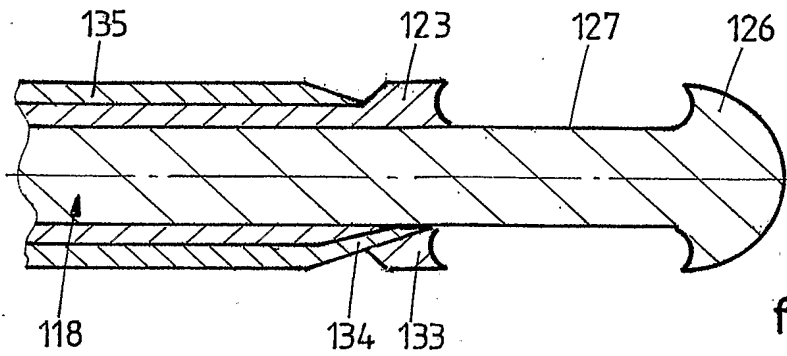

fig.13a

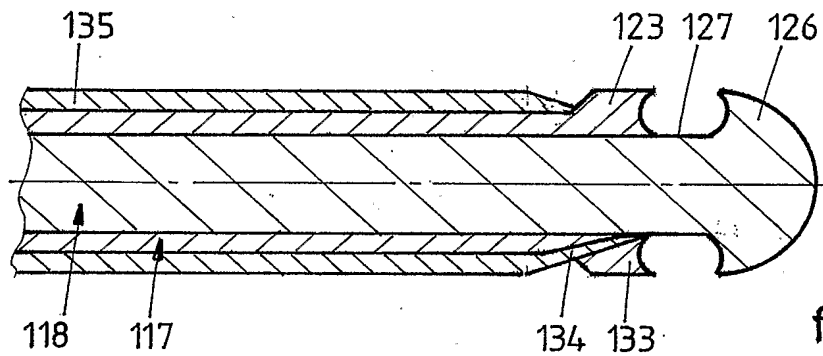

fig.13 b

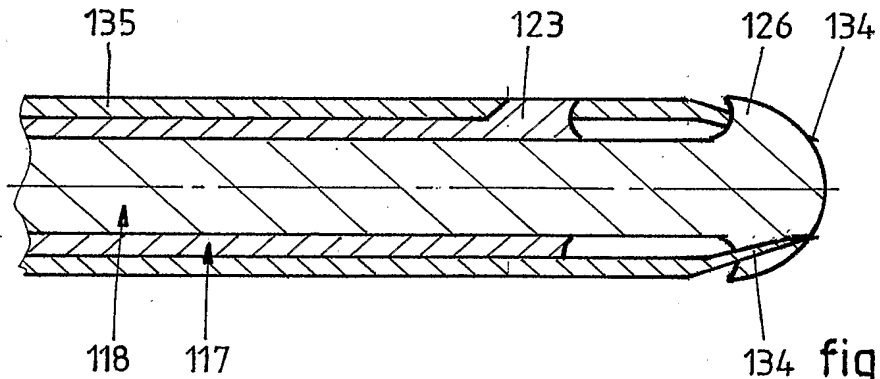

fig.13c

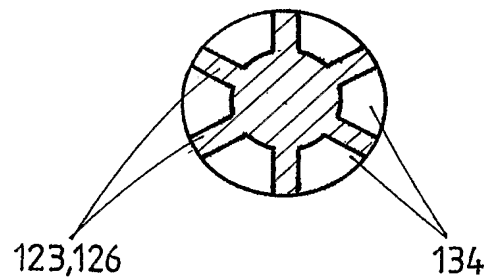

fig.12

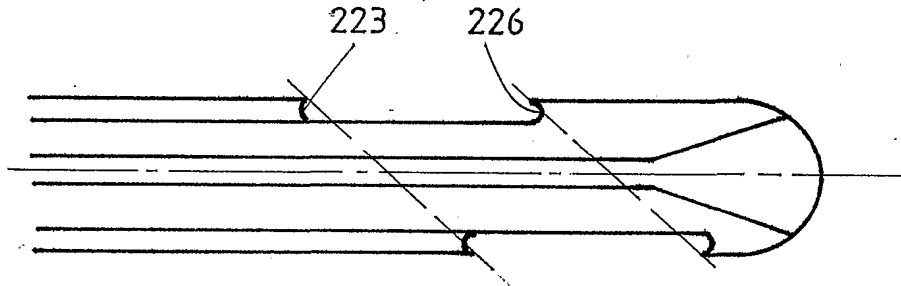

fig.15

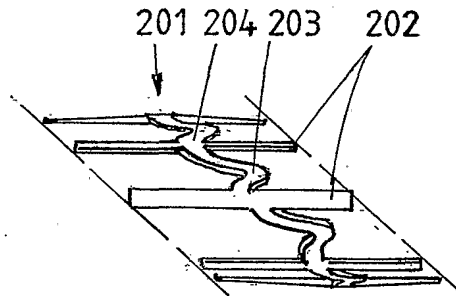

fig.14

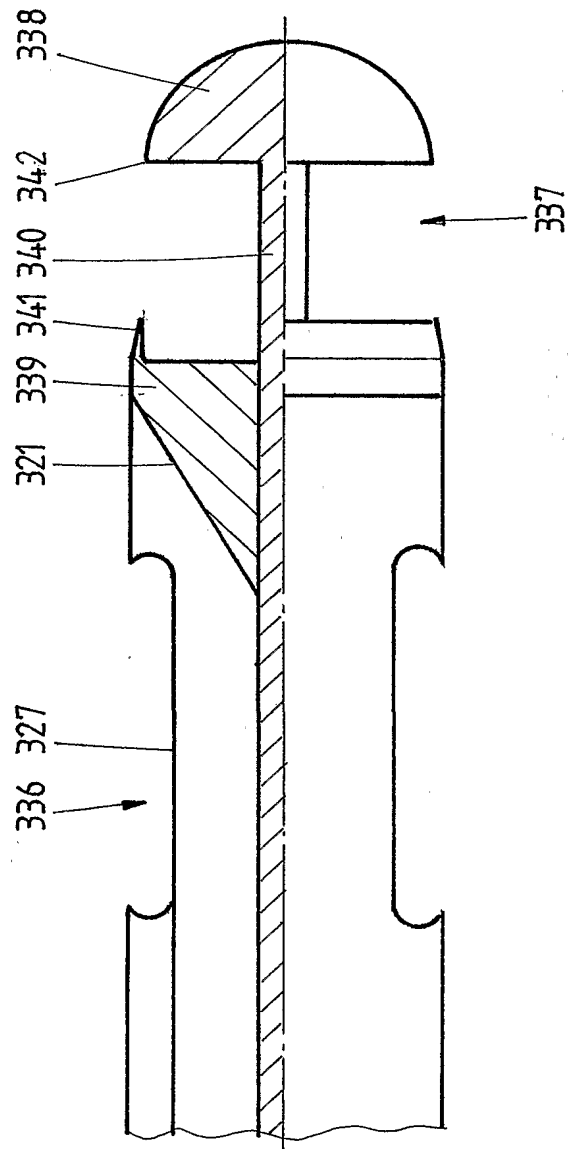

fig.16

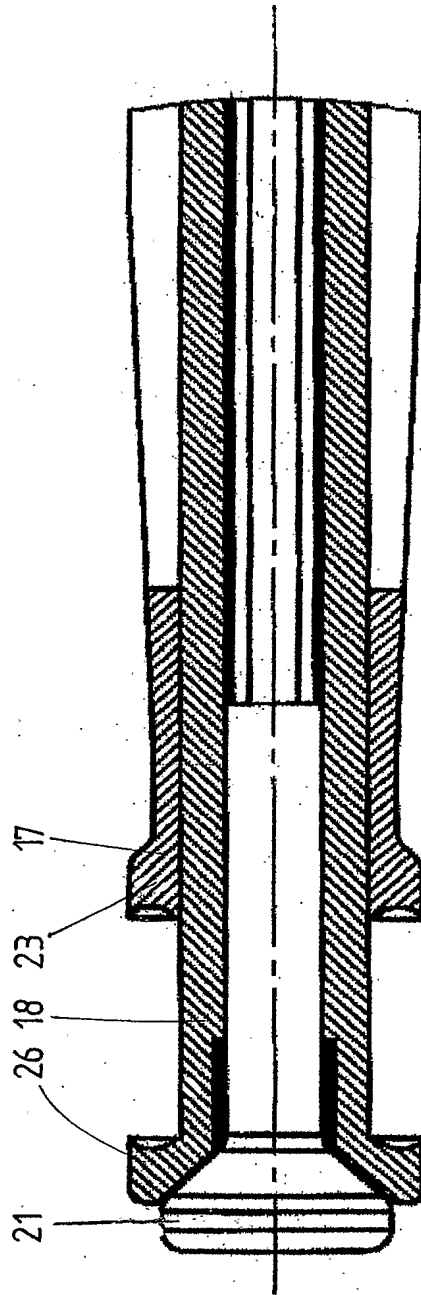

fig.17

11/13

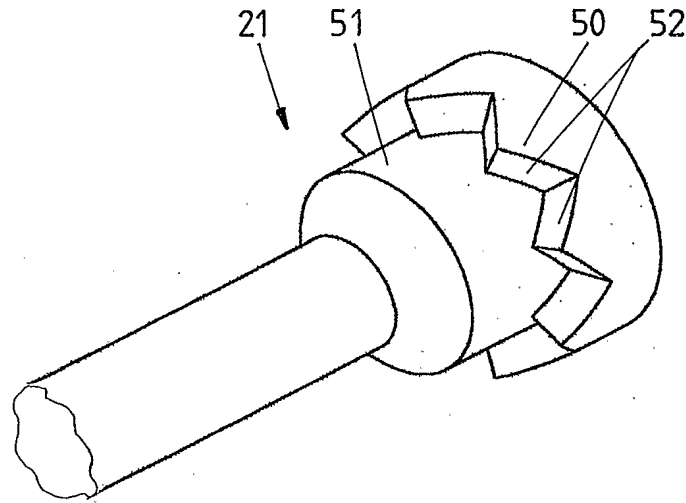

fig.19

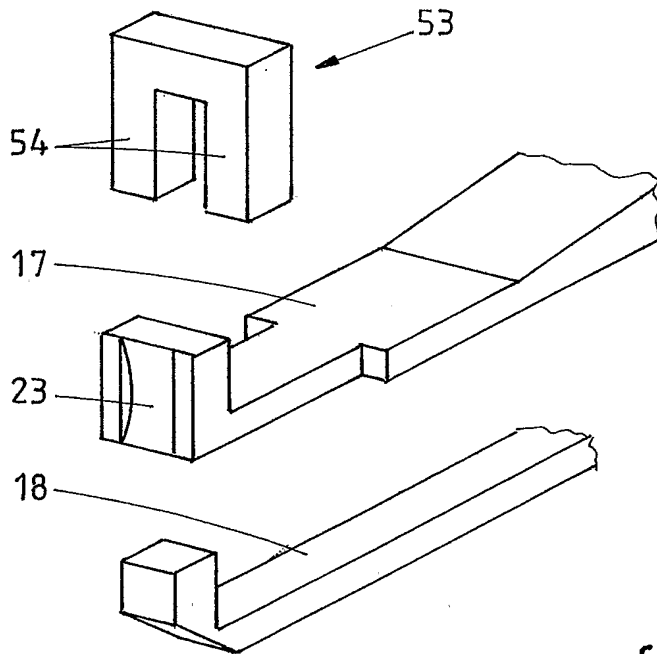
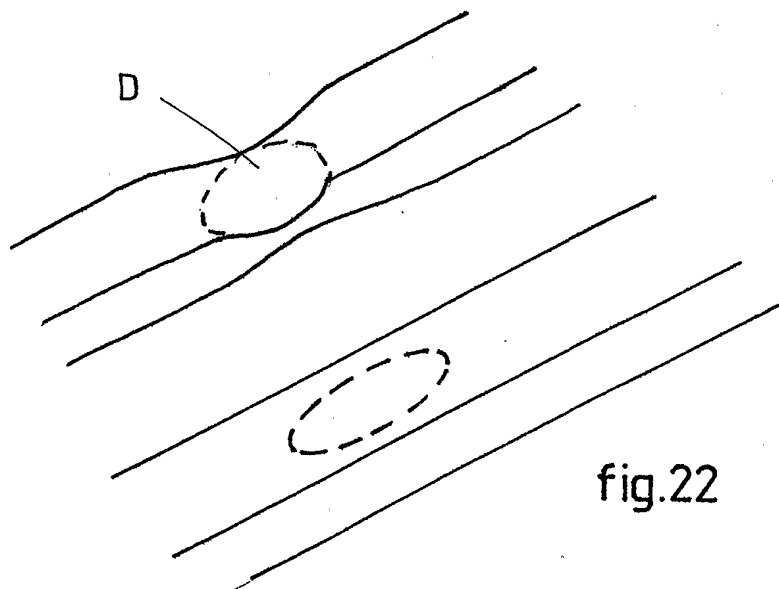
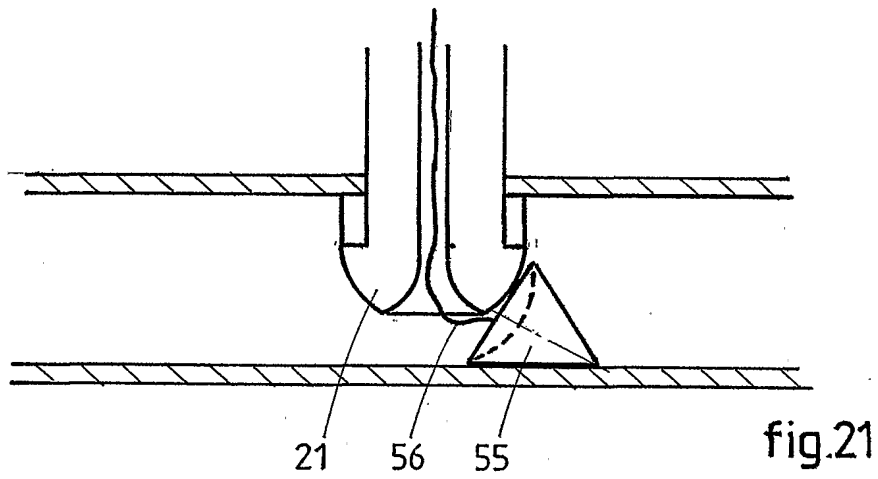
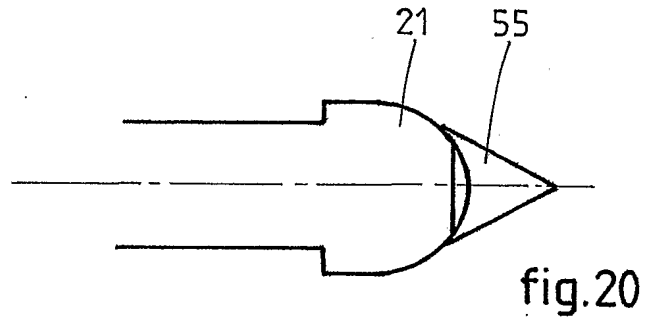

fig.18



12/13



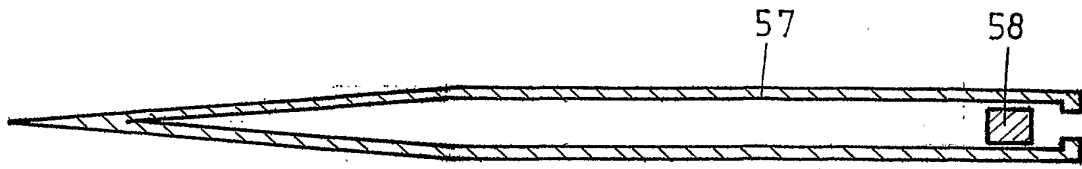

fig.23

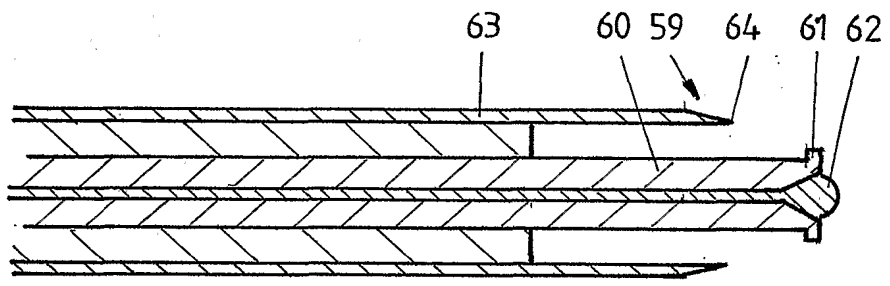

fig.24A

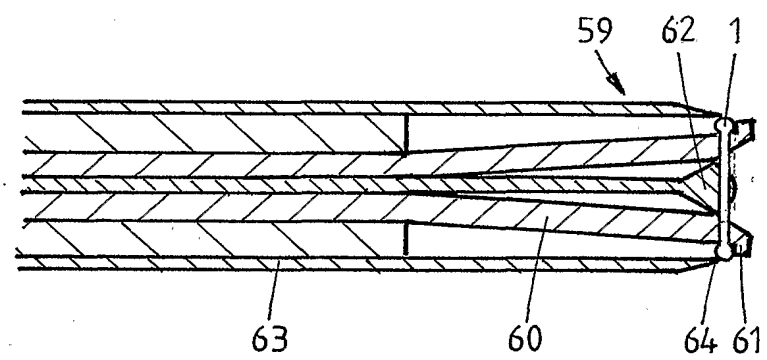

fig.24B